

Item #: 180MW1000D

## Commercial Microwave with dial timer & stainless steel cavity



120V 1000W



### Features

- 6 minute dial timer with easy to read LED indicators to ensure accuracy
- Interior oven light
- Stainless steel exterior provides a sleek appearance
- Deep stainless steel interior gives this microwave a clean look
- 4 legs provide a 1 $\frac{3}{4}$ " clearance from the countertop
- See-through door and lighted interior allows the user to monitor cooking
- 6 month replacement warranty

### Dimensions

Capacity	.9 cu. ft.
Unit Dimensions	20"W x 12"H x 18.5"D
Oven Cavity Dimensions	13"W x 8"H x 13.25"D
Shipping Weight	39 lbs.
Product Weight	34 lbs.

### Electrical

Voltage	120V
Hz	60 Hz
Phase	Single
Wattage	1000W
Usage Level	Light Duty

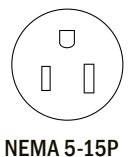
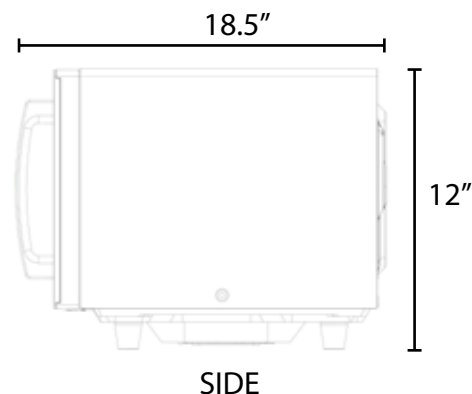
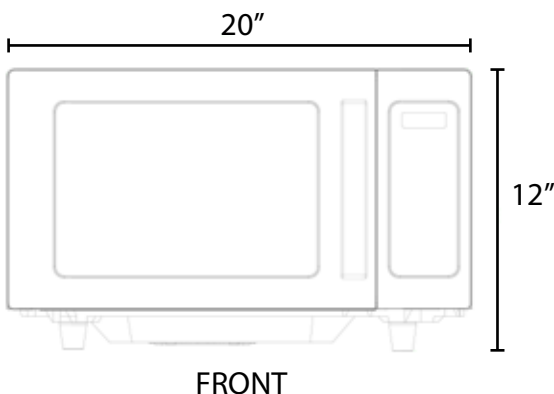
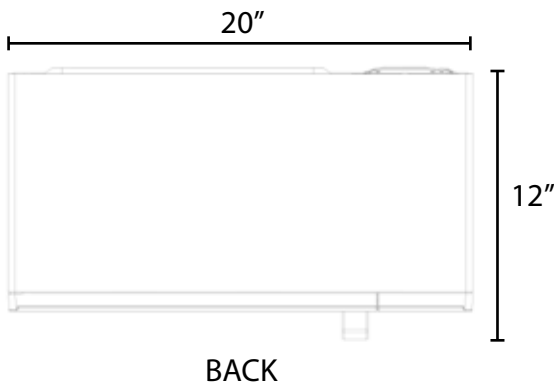

NEMA 5-15P