

1 2 3 4 5 6

A

B

C

D

E

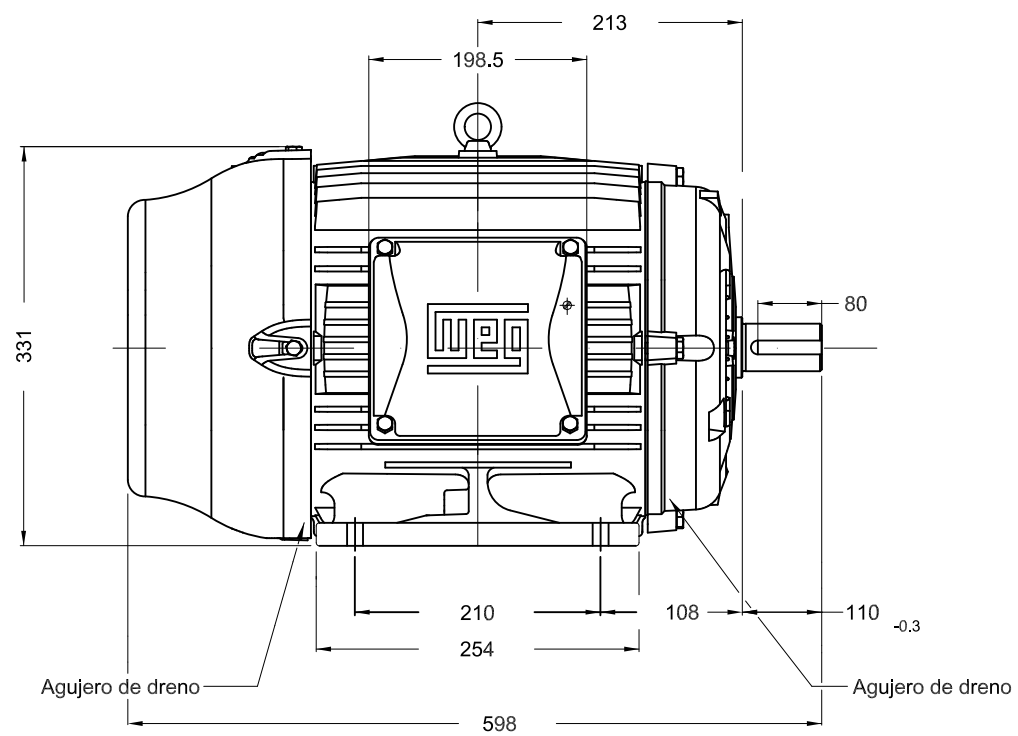
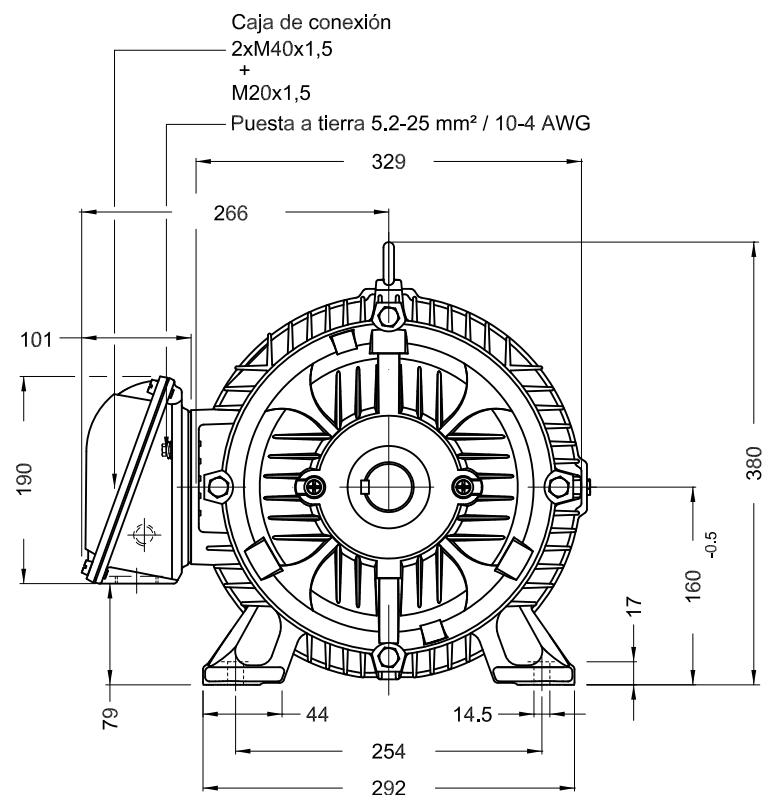

15 kW (20 HP) 04 Polos 60 Hz A

Sin tornillo nivelacion vertical  
Color RAL 5009  
Plan de pintura 203A  
Forma constructiva B3L(D)

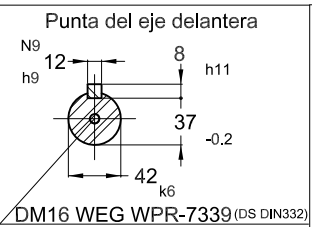

No MODIFICACION	LOC	RESUMEN DE MODIFICACIONES	EJECUTADO	VERIFICADO	LIBERADO	FECHA	VER
EJEC.	HYBRISUSER	MOTOR TRIF. W22 IE3					
VERIF.		CARCASA 160M IP55 TEFC					
LIBER.							
FECHA LB.	WMO	Jaragua do Sul	Ingeniera del Producto	HOJA	1 / 1		

PREVIEW  
WDD

