

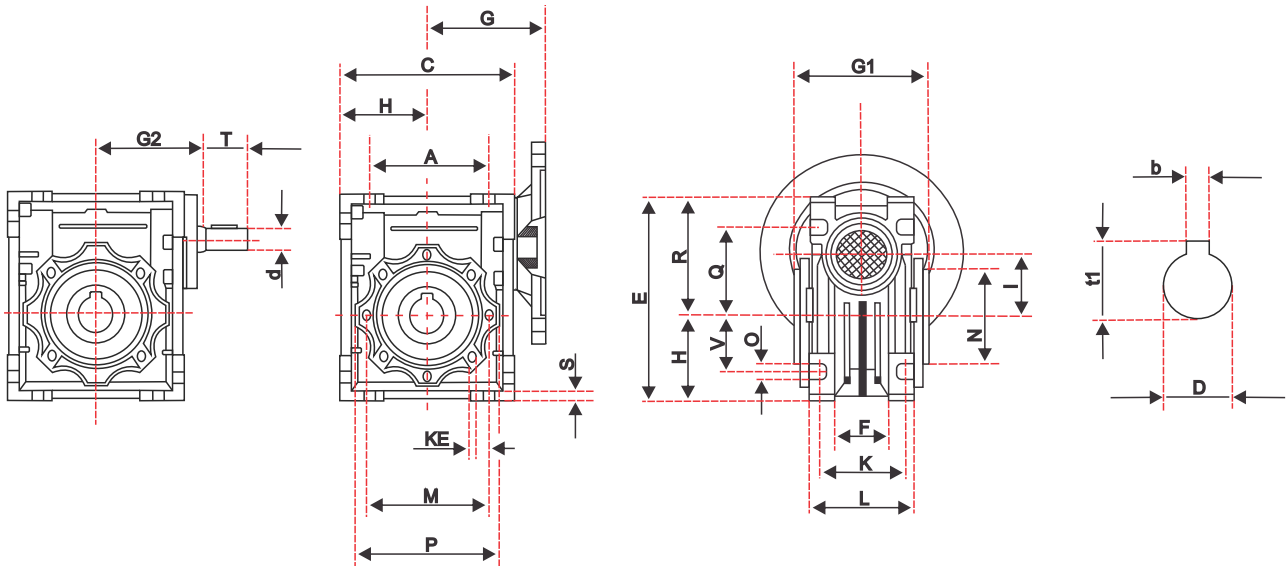

DIBUJO DIMENSIONAL, BRIDAS, RELACIONES Y VELOCIDADES DISPONIBLES

## REDUCTOR SINFIN CORONA TAMAÑO 130



A	C	D	E	F	G	H	I	L	M	N	O	P	Q	R	S	T	V	K	N1	KE	$\alpha$	d(j6)	b	t1
200	292,5	45	335		$\leq 179$	147,5	130	155	215	180	16	250	140	187,5	15	80	100	120	81	M12X20(n8)	45°	30	14	48,8



Tabla de Datos (Motor 4 polos, 1800 rpm)

Type	RATIO	RPM	HP	Nm	sf
130	7,5	240	10	266,7	1,8
	10	180	10	352,3	1,5
	15	120	10	531,1	1,1
	20	90	10	672,1	0,8
	30	60	7,5	713,3	1,1
	40	45	7,5	910,7	0,9
	50	36	7,5	1072,5	0,7
	60	30	5	922,4	0,8
	80	22,5	3	673,9	1
	100	18	3	765,3	0,8

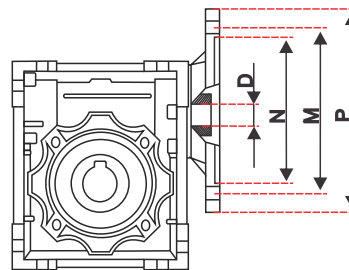

REFERENCIA	TIPO DE FLANCHE IEC	N	M	P	RELACION											
					7,5	10	15	20	25	30	40	50	60	80	100	
					D											
NMRV130	90B5	130	165	200	/	/	/	/	/	/	/	/	/	/	24	24
	100/112B5	180	215	250	/	/	/	/	28	28	28	28	28	28	28	28
	132B5	230	265	300	38	38	38	38	38	38	38	38	/	/	/	/