

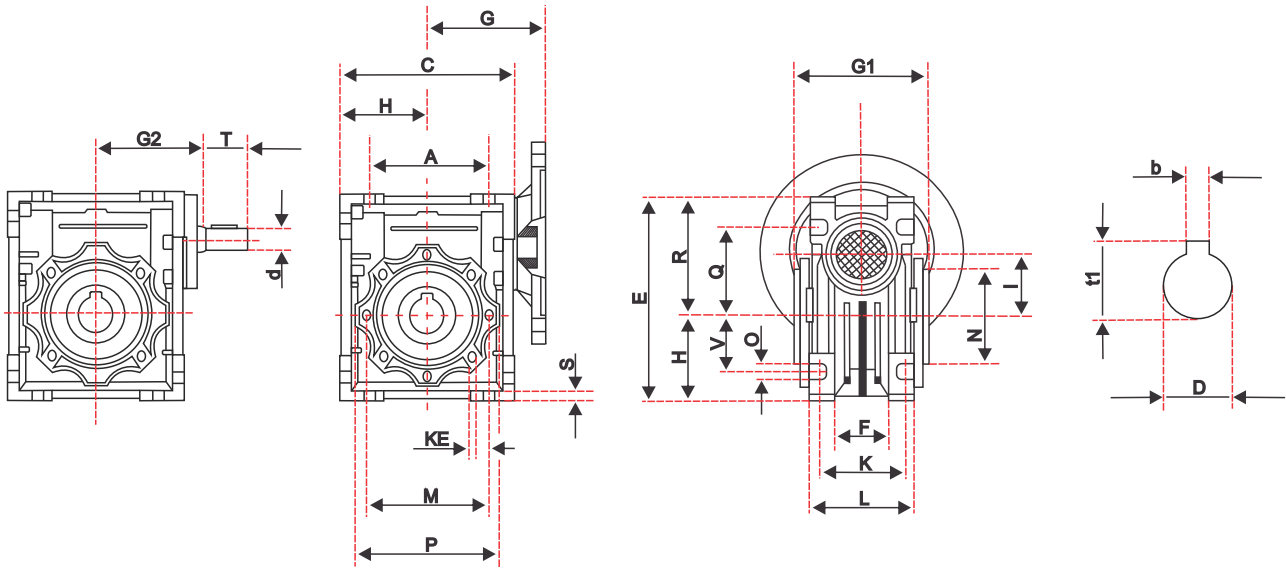

DIBUJO DIMENSIONAL, BRIDAS, RELACIONES Y VELOCIDADES DISPONIBLES

REDUCTOR SINFIN CORONA TAMAÑO 30



A	C	D	E	F	G	H	I	L	M	N	O	P	Q	R	S	T	V	K	N1	KE	α	d(j6)	b	t1
54	80	14	97	32	≤54	40	30	56	65	54	6,5	75	44	57	5,5	20	27	44	29	M6X11(n4)	0°	9	5	16,3



Tabla de Datos (Motor 4 polos, 1800 rpm)

Type	RATIO	RPM	HP	Nm	sf
30	7,5	240	1/4	5,4	1,9
	10	180	1/4	7,1	1,5
	15	120	1/4	10,1	1
	20	90	1/4	13,2	0,8
	30	60	1/8	17,6	0,8
	40	45	1/8	18,4	0,9
	50	36	1/8	18,8	0,8
	60	30	1/12	9,3	0,9
80	22,5	1/12	10,8	0,9	

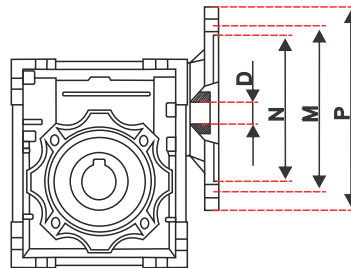

REFERENCIA	TIPO DE FLANCHE IEC	N	M	P	RELACION											
					7,5	10	15	20	25	30	40	50	60	80	100	
					D											
NMRV30	56B14	50	65	80	9	9	9	9	9	9	9	9	9	9	9	/
	63B14	60	75	90	11	11	11	11	11	11	11	11	11	11	/	/
	63B5	95	115	140	11	11	11	11	11	11	11	11	11	/	/	/