

Ultra-2 HP WHT/SST Manual Fill -Std Hdl

31.9" x 24.5" x 16.0"
(81.0cm x 62.2cm x 40.6cm)



- Patented beverage monitoring technology and reversing auger design ensure consistent, great tasting frozen beverages
- Two large product hoppers hold 3 gallons (11.4L) each to maximize serving capacity
- User interface communicates need for cleaning and maintenance, and provides simple programming, cleaning and preventive maintenance guides to ensure reliable operation and performance – minimizing down time and maximizing serving capacity and profits
- LED lighted merchandisers in hopper lids bring high visibility to front- of-house applications
- Standard Dispense Handle
- Sanitation listings NSF 18 and NSF 6 (Dairy)

Agency:



Specifications

Product #: 34000.0534

Legs: 4" Black Legs

Autofill: None

Finish: Stainless/White

Hoppers: Two

Refrigerant: R404A

Additional Features

Electrical & Capacity

Volts	Amps	Watts	Cord Attached	Plug Type	8oz cups/hr 236ml cups/hr	Input H ² O Temp.	Phase	# Wires plus Ground	Hertz
120	12	1440	Yes	NEMA 5-15P	-	60°F (15.5°C)	1	2	50/60

Plumbing Requirements

PSI	kPa	Fitting Supplied	Water Flow Required (GPM)
-	-	-	-

CAD Drawings

2D	Revit	KLC
●		



BUNN® reserves the right to change specifications and product design without notice. Such revisions do not entitle the buyer to corresponding changes, improvements, additions or replacements for previously purchased equipment. For most current specifications and other info visit bunn.com.

Created on:
04/11/2019

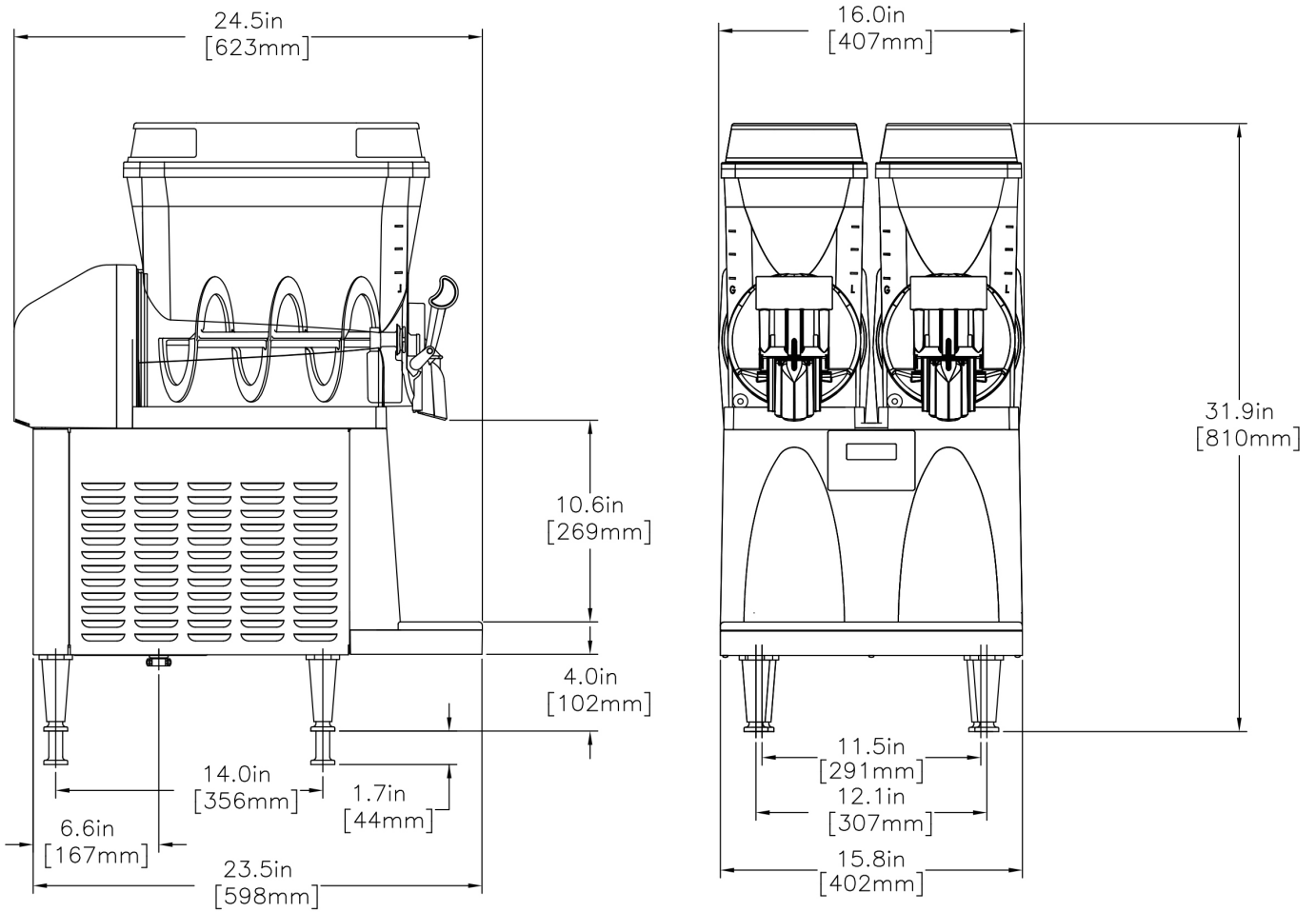
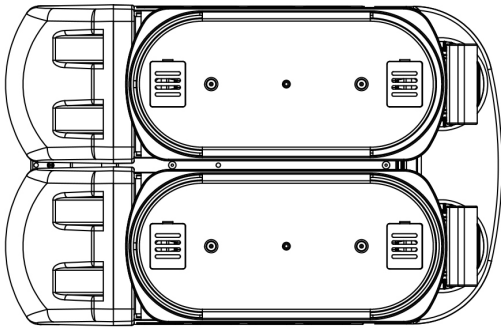

Unit			Shipping					
	Width	Height	Depth	Width	Height	Depth	Weight	Volume
English	16.0 in.	31.9 in.	24.5 in.	-	-	-	134.410 lbs	-
Metric	40.6 cm	81.0 cm	62.2 cm	-	-	-	60.968 kgs	-



BUNN® reserves the right to change specifications and product design without notice. Such revisions do not entitle the buyer to corresponding changes, improvements, additions or replacements for previously purchased equipment. For most current specifications and other info visit bunn.com.

Created on:
04/11/2019

Related Products & Accessories: Ultra-2 HP WHT/SST Manual Fill -Std Hdl(34000.0534)



DRIP TRAY ASSY,
LOWER-BLK

Product #: 28086.0001

COVER, DRIP TRAY
ULTRA 2 BLK

Product #: 32068.0001



BUNN® reserves the right to change specifications and product design without notice. Such revisions do not entitle the buyer to corresponding changes, improvements, additions or replacements for previously purchased equipment. For most current specifications and other info visit bunn.com.

Created on:
04/11/2019

Serving & Holding Options: Ultra-2 HP WHT/SST Manual Fill -Std Hdl(34000.0534)

Serving and Holding selections are currently unavailable. Please contact your sales representative to find out more information.



BUNN® reserves the right to change specifications and product design without notice. Such revisions do not entitle the buyer to corresponding changes, improvements, additions or replacements for previously purchased equipment. For most current specifications and other info visit bunn.com.

Created on:
04/11/2019