

EJE	
ESTÁNDAR	X
OPCIONAL	
ESPECIAL	

Dimensões em mm
Dimensiones en mm

ESTA REVISION SUBSTITUYE Y ANULA LA EMISION ANTERIOR, LA CUAL DEBERA SER ELIMINADA.

A

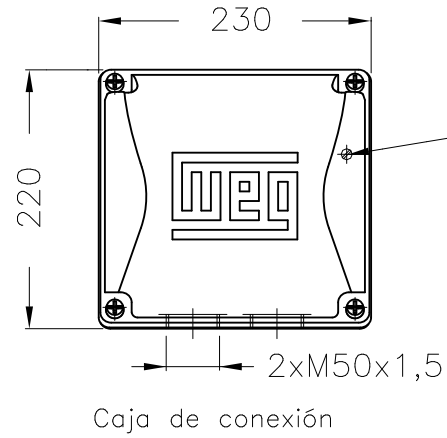

B

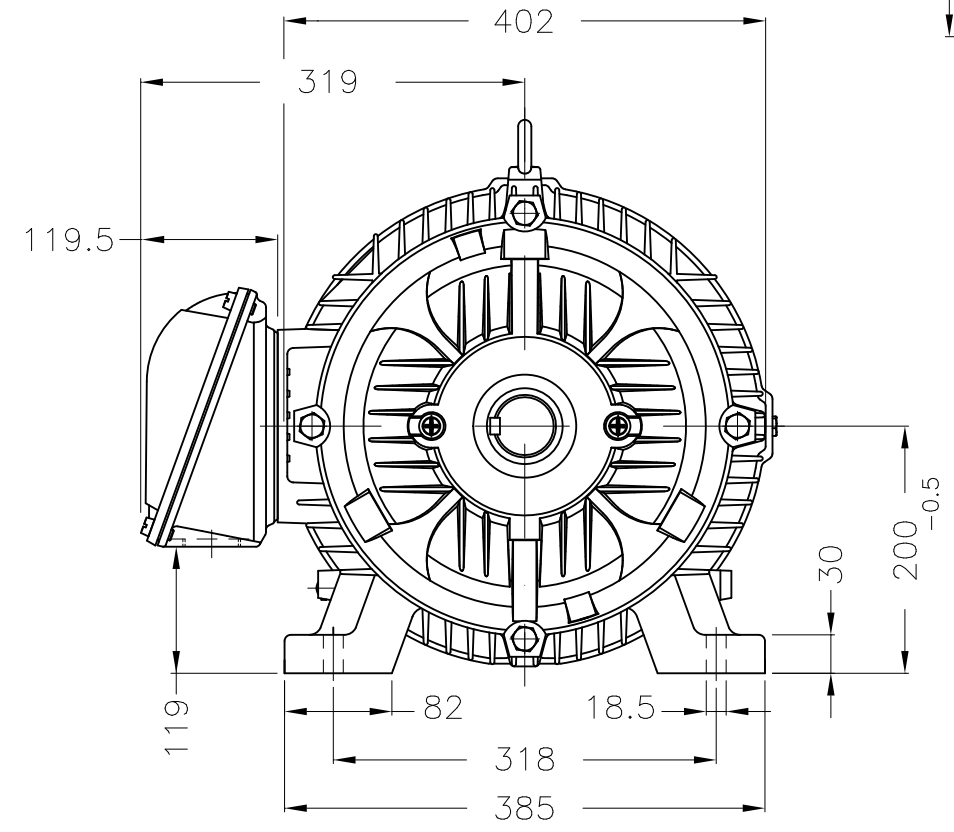

C

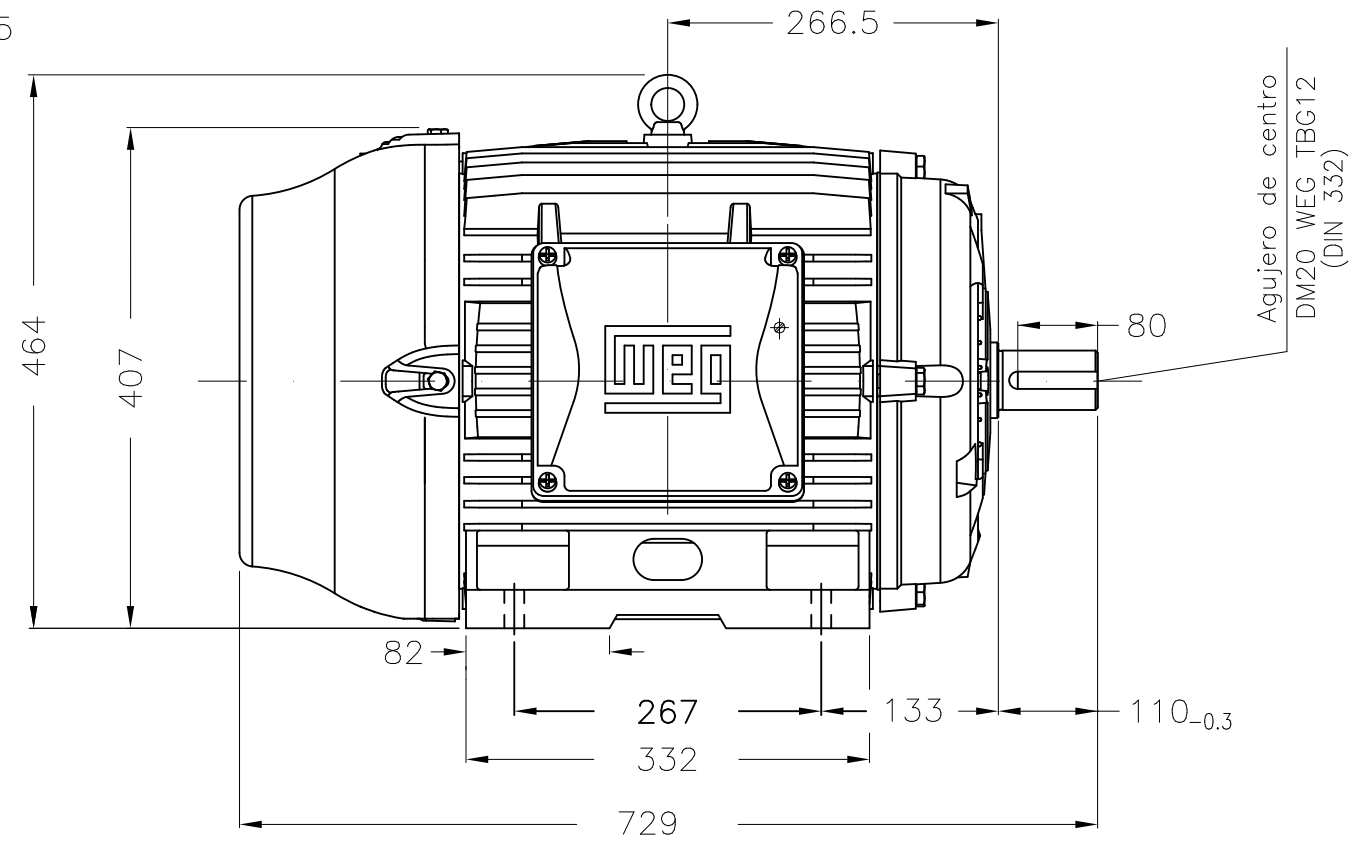

D

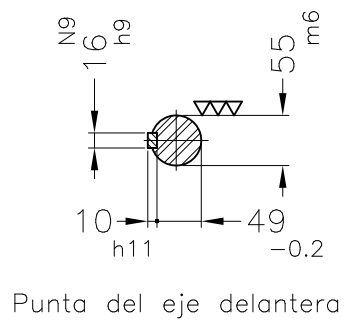

E

Color RAL 5009
Plan de pintura 203A
Forma constructiva B3L(D)

No MODIFICACION ECM	LOC LOC	RESUMEN DE MODIFICACIONES SUMMARY OF MODIFICATIONS	EJECUTADO EXECUTED	VERIFICADO CHECKED	LIBERADO RELEASED	FECHA DATE	VER VER
EJEC. /EXECUTED	USERADMIN	MOTOR TRIFASICO W22 - PLUS CARCASA 200M IP55 TEFC Código WEG: 11571350					
VERIF. /CHECKED							
LIBER. /RELEASED							
FECHA LÍ/REL DT	02.04.2019	WMO Jaragua do Sul	Ingeniera del Producto	HOJA/SHEET	1 / 1		

30 kW (40 HP) 02 Polos 60Hz

