

EJE	
ESTÁNDAR	X
OPCIONAL	
ESPECIAL	

Dimensões em mm
Dimensiones en mm

ESTA REVISION SUBSTITUYE Y ANULA LA EMISION ANTERIOR, LA CUAL DEBERA SER ELIMINADA.

A
B
C
D
E

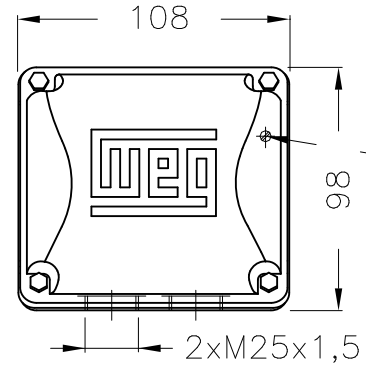
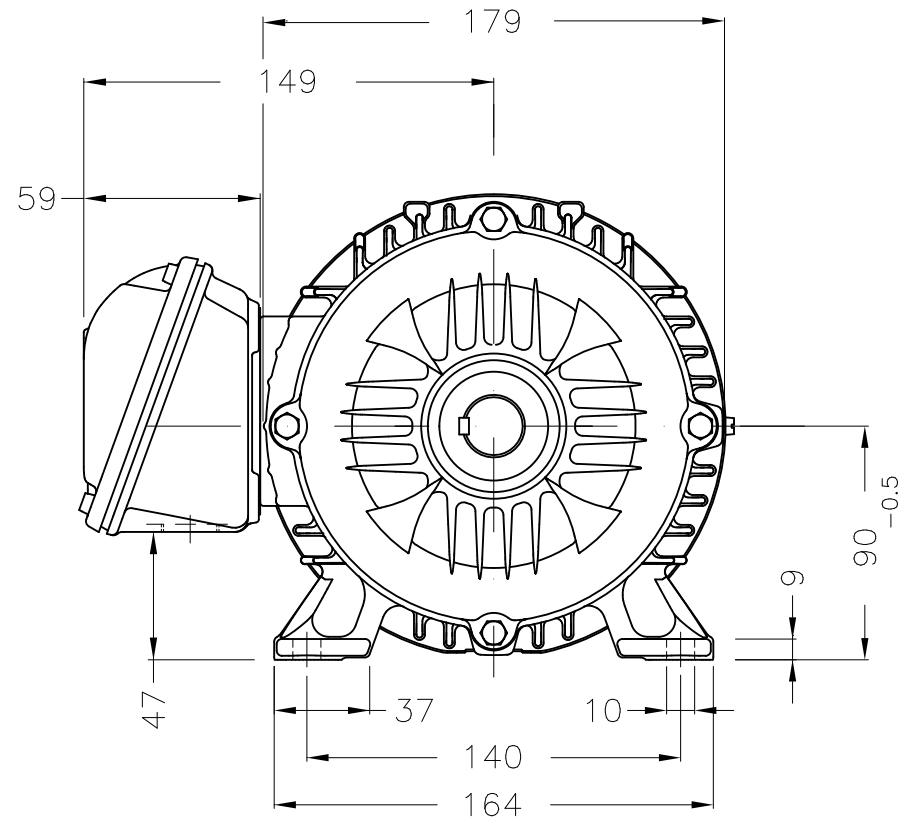

Caja de conexión

Puesta a tierra 0.5-6 mm² / 20-10 AWG

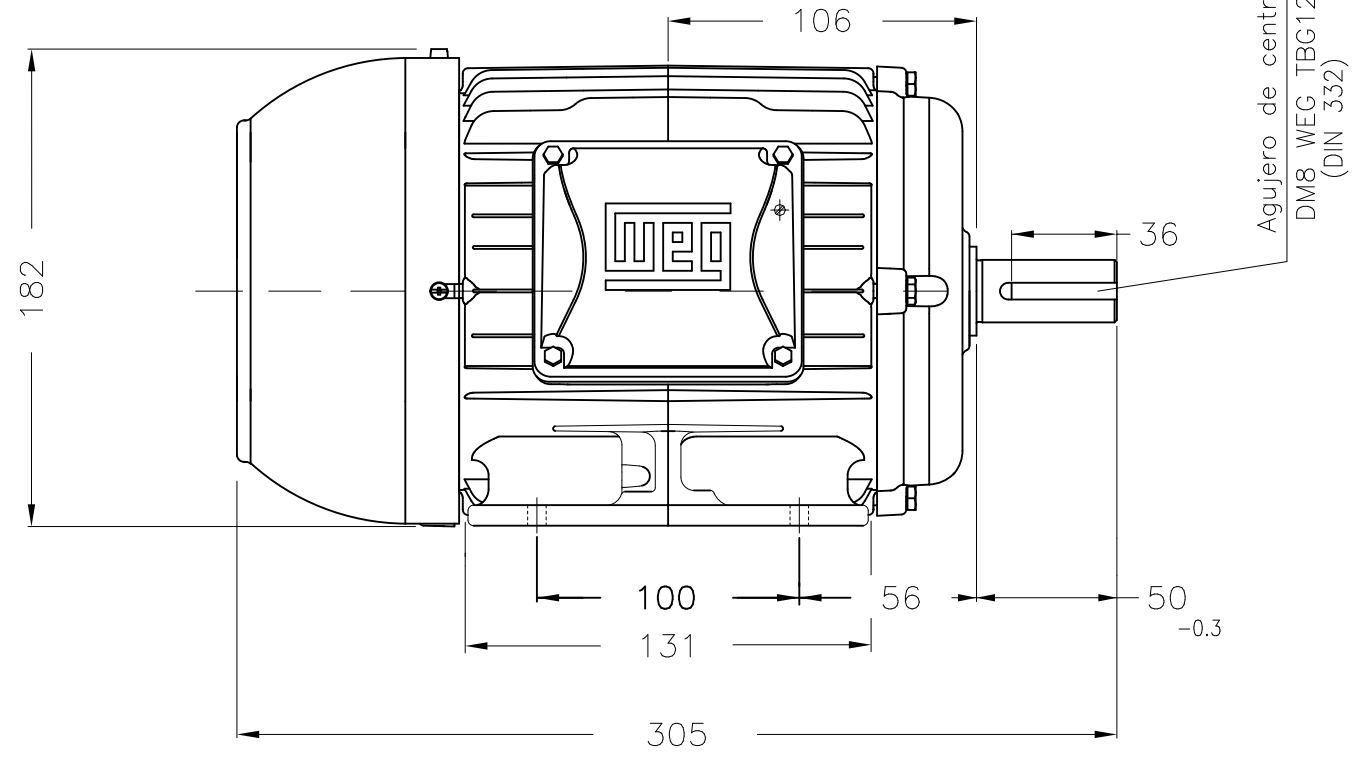

Agujero de centro
DMB WEG TBC12
(DIN 332)

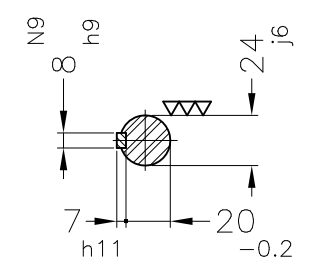

Punta del eje delantera

Color RAL 5009
Plan de pintura 207A
Forma constructiva B3L(D)

No MODIFICACION ECM	LOC LOC	RESUMEN DE MODIFICACIONES SUMMARY OF MODIFICATIONS	EJECUTADO EXECUTED	VERIFICADO CHECKED	LIBERADO RELEASED	FECHA DATE	VER VER
EJEC. /EXECUTED	USERADMIN	MOTOR TRIFASICO W22 - PLUS					
VERIF. /CHECKED		CARCASA 90S IP55 TEFC					
LIBER. /RELEASED		Código WEG: 11789828					
FECHA LÍ/REL DT	30.03.2019	WMO Jaragua do Sul	Ingeniera del Producto	HOJA/SHEET	1 / 1		

1,5 kW (2 HP) 04 Polos 60Hz

A

